

Isotherm 4201/4701 ASU Magnum

Operation and installation manual

GENERAL

Isotherm 4201/4701 ASU Magnum is a modern seawater cooled refrigeration system for sailing yachts and motor cruisers. It is designed to generate low refrigeration temperatures also in the warmest conditions while at the same time consuming an absolute minimum of battery power.

This is achieved by using our patented electronic control system ASU that runs the compressor at 75 % higher speed when the boats engine is running.

This in combination with a holding plate inside the refrigerator, stores the refrigeration energy produced for long periods.

Safety

For your own and others safety, please read this first.

When connected to shore power, ensure that the power supply is equipped with an earth leak switch. **Danger!**

A battery charger must be connected to the battery, never direct to the refrigeration system.

In addition to acid, a newly charged battery contains explosive gas. **Danger!**

Never touch bare electric wiring or contacts connected to the mains supply. **Danger!**

Never open the refrigerant circuit except by the quick-couplings, which are of self-sealing type and designed for this purpose.

The refrigeration unit must be disposed by a refrigeration specialist for correct recycling of components and care taking of the refrigerant.

The following points are important, to achieve a good result:

Refrigerator box

To retain as much cold air as possible when opened, a top-loading box is usually preferable to a side opening one.

A most important factor in achieving good results is that the refrigeration box is well insulated. Do not use polystyrene type material. Expanded or cross-linked PVC or polyurethane insulation material should be used. Recommended insulation thickness (multiply by 3 for freezers): 30 mm for up to 50 litre boxes; 50 mm for up to 100 litres and 75 – 100 mm for larger boxes. If space is available use thicker insulation around the lower part and in the bottom.

A moveable partition should be installed in the box to allow the frozen food section surrounding the cold plate to be reduced to the smallest space possible so that the correct temperature of 4 – 6°C (39 – 43°F) can easier be maintained in the refrigeration section. The lid must also be insulated but more important that it fits tightly into the opening. If a water drain is fitted in the bottom of the box, this must always be closed during use to avoid cold air from running out and warm damp air entering.

Electrical system

An electrical system that is both correctly dimensioned and in good working order is required. This is especially important if the refrigeration system is to operate continuously for a few days during warm weather and not have to start the engine for charging.

Calculate the boats total power requirements. The engine should always have a separate battery for starting. In addition to the battery capacity required for other electrical equipment

on board, one additional battery 75-100 Ah will be sufficient for the refrigeration power supply.

In addition to increasing the amount of “standby” power available on board, the extra service battery can also store surplus power when the engine is generating this. Two batteries can, of course, accept twice the amount of charge. The alternator is normally not a limiting factor. All service batteries shall be connected to a “battery bank” and must have generously-dimensioned cables for both positive and negative circuits if they are to receive full charging voltage from the alternator.

Using the refrigerator

Power consumption is dependant to a large degree on how the refrigerator is used. Let refrigerated food remain inside the fridge as far as possible and take them out only when required. Don't leave them out of the fridge longer than absolutely necessary when cooking or having your meal. Put them back as quickly as possible. Avoid placing warm food in the fridge. If possible, use an insulated thermal bag when carrying frozen or chilled foodstuffs from home or the shop. Let the engine run for a while extra when leaving or approaching the harbour. The engine alternator will then supply an extra boost of refrigeration energy just when needed, i.e. immediately before non-power periods of sailing or in harbour.

Refrigeration temperatures

The correct temperatures for storing sensitive foodstuffs such as meat, fish, milk products etc, are as follows:

Internal temperature of refrigerated food	Duration after which food can become unfit for consumption
10°C (50°F)	1 day or less
8°C (46°F)	1-2 days
6°C (43°F)	2-3 days
4°C (39°F)	5 days
1°C (34°F)	5-7 days

The correct way to store refrigerated food is to never allow its temperature to exceed 6°C (43°F). Switching off the refrigerator overnight is a false economy and from a hygienic point in view it is not recommended.

MAIN COMPONENTS

The Isotherm refrigerator system consists of three main components; the compressor unit, the holding plate and the control panel.

Compressor unit – Fig. A

The Danfoss BD50F dual volt 12/24 V refrigeration compressors are of the very latest design and produces extremely high refrigeration energy while consuming very little battery power. As it is driven by 3-phase alternating current, it has an unbeatable starting ability and the speed and capacity can be regulated. It is of the same totally hermetic design as that of domestic refrigerators and has a long operating lifetime, low noise level and is completely maintenance free.

The piston type compressor operates on a mixture of refrigerant and oil. The compressor unit are to be mounted horizontally but it will operate at a continuous angle of heel up to 30° in all directions. Should this angle be exceeded, the compressor will stop automatically. It will re-start automatically when the angle has been reduced.

The compressor is integral with the water-cooled condenser, which is equipped with a water pump.

The compressor unit is delivered pre-filled with refrigerant and has irreversible quick coupling connections on the ends of the flexible piping which connects it to the holding plate. These couplings can be disconnected and re-connected should either unit need re-positioning.

To simplify connecting up the system, the electronic control unit mounted on the side of the compressor is fitted with tab-type terminals for the positive and negative main power supply cables, modular connectors for the temperature sensors and the control panel cables.

The modular connectors have different sizes to prevent incorrect connection. The electronic units contains micro-processors with programs for slow running, speeding up the compressor when the engine is running, battery monitoring for high and low voltage, automatic de-frosting, water pump control, regulating the holding plate temperature, transmitting signals to the control panel etc.

The compressor and the electronic units fulfil applicable radio interference regulations (EMC) and are CE-marked.

When connected to shore power, a high quality marine battery charger of minimum 15A output should be used. The battery charger must always be connected to the batteries and never direct to the refrigeration system.

Holding plate – Fig. B

The holding plate is a hermetic, stainless steel container holding a special cooling medium, which freezes to ice when the engine is running. The freezing point of the liquid is normally -8°C (17°F). The holding plate is connected to the compressor unit by a pliable, 3 meter (~10 foot) long tinned copper pipe of 6 mm ($\frac{1}{4}$ " diameter) fitted with quick coupling connectors.

The holding plate must be fitted as high as possible in the refrigerator. It may be installed in any vertical or horizontal position required and at any level above or below that of the compressor unit.

A temperature sensor is fitted to the rear of the holding plate. This is to be connected to the compressor unit by the cable and can suitably follow the same route as the connecting pipe. This pipe, together with the compressor unit and the holding plate, is pre-filled with the correct amount of refrigerant and on no account should any attempt be made to either shorten or lengthen the pipe. If the pipe is too long, the excess should be made into a coil at some suitable position. If a longer pipe is required, pre-filled 1.5, 2 and 2.5 metre extension pipes are available.

A 2.5 metre (8 ft.) extension for the temperature sensor cable is also available, Part no. 39232.

Control panel – Fig. C

The control panel is equipped with a three-way switch, green, yellow and red indicator lights and a rheostat for manual temperature setting when running on shore power or on solar panels.

The system is switched off when the switch is placed in mid-position.

Upper position is MAN.TEMP and lower position is NORMAL.AUTO.

The control panel has a modular connector for the 4 metre (13 ft.) control cable from the electronic unit. Should this require extending, use the 10 metre (33 ft.) accessory control cable instead. Part no. 39230.

The control panel is normally placed near the refrigerator.

OPERATION

The Isotherm ASU Magnum can be operated in two ways. In NORMAL.AUTO or MAN.TEMP.

When energy saving is needed, switch to NORMAL.AUTO working mode. Optimum refrigeration temperature is then automatically maintained while consuming the lowest amount of battery power possible.

When there is no need of energy saving, switch to MAN.TEMP working mode. The automatic functions are now partially blocked and the refrigeration temperature can be manually adjusted. (Fig. C)

By means of the three-way switch on the panel the refrigeration system is started, stopped and working modes are selected. Working mode is indicated on the indicator lights to the right of the switch. No indicator light on means the system is off.

Operation in NORMAL.AUTO

The green light indicates that power is being supplied and the refrigeration system is on. When the engine is running and the voltage supply is over 13.2 (26.4) volt (measured on the compressors control unit), the compressor starts to supply cooling energy to the holding plate. It starts within the first 30 seconds and operates first at low speed with the yellow indicator light “Economy” on and after half a minute, the speed of the compressor increases by 75% and the red indicator light “Freeze” comes on instead of the yellow. This operating condition is maintained until the holding plate is completely frozen at approx. -14°C (7°F). This can take between 45 minutes and 2 hours depending on box size, box insulation and ambient temperature. On reaching this temperature, the compressor stops and the red light goes out and only the green will remain on. When the temperature of the holding plate rises to -10°C (14°F), the compressor restarts to charge the holding plate and the red light comes on again. This process is repeated a couple of times every hour keeping the holding plate at its optimum efficiency level.

When the engine is stopped, the compressor also stops shortly afterwards when the battery voltage has gone down to 12.7 (25.4) volt. The surplus of refrigeration energy stored in the holding plate is now used first. Only when this has been consumed does the compressor start again. The yellow light indicates that it is now running, in the first hand, at its low “Economy” speed to top-up the holding plate only. This working condition starts when the temperature of the holding plate rises to -1°C (30°F) and stops when it reaches the economy level of -6° (21°F).

Operation in MAN.TEMP

This position can be used either when shore power or solar panels are being used or when energy saving is not required and a higher or a lower refrigeration temperature is desired for some reason. The automatic function is partially blocked and the temperature can be set manually on the rheostat – clockwise for colder and anti-clockwise for warmer. “A” indicates the holding plate temperature point for “Accumulation”, abt. -8° (46°F).

In the MAN.TEMP working mode, the compressor starts and runs in the first hand in low speed to maintain the temperature level selected. If the difference between chosen and real temperature is more than 6°C , the compressor will automatically speed up for faster cooling down. As soon as this extra power is not needed, the compressor speed will be reduced for lowest power consumption and to keep selected temperature.

Indicator lights

Green:	Power and system on, the compressor is stand-still due to sufficiently low temperature of the holding plate.
Green + yellow:	Compressor running within the higher temperature range
Green + red:	Compressor running within the lower temperature range.
Green + yellow + red:	Compressor running at lowest possible speed to reach selected temperature in MAN.TEMP working mode.
Flashing yellow + red:	Error signal from the electronic unit. Automatic re-start after 1 minute.
Flashing yellow:	Low battery voltage sensor has switched off the system. Automatic re-start occurs when engine is started to charge the batteries again.

Note: The compressor will start 30 seconds after switching on. When the engine is started, ½ to 10 minutes are required, depending on the boats charging equipment and battery condition, before the system reacts. When the engine is stopped, ½ to 5 minutes are required, depending on battery condition and level of charge, before the system reacts. Defrosting will take place automatically every tenth day of operation. If so preferred the defrosting can be avoided by means of switching off the system for a minute. The counter will than start from 0 again.

Water pump system

The water pump power supply is connected to a voltage reducer unit for flow regulation to give enough cooling with lowest possible power consumption and noise level.

Maintenance is limited to a periodically, at least once a year, check and when so is needed exchange of the zinc anode placed in the outgoing water Tee connector.

Clean also periodically the water filter, interval depending on the water quality.

Drain the water system, including the pump and filter, if temperatures below freezing point are expected.

Maintenance

If the quick couplings have been tightened correctly during installation, the totally hermetic system will never require re-filling of refrigerant. Maintenance is limited to removing dust and dirt from the compressor and condenser unit, regular check-up and re-placement of the zinc anode, cleaning water filters, defrosting the holding plate when required and keeping the box inside dry and clean to prevent bad air.

It is of vital importance that the batteries and the charging system are kept in good condition. The complete system should remain on board during the winter, but it may not always be able to be started at ambient temperatures below freezing.

Drain the water pump, filters and hoses if temperatures below freezing are expected.

Technical data

Type designations:	4201, 4701
Capacity 4201:	Holding plate 355x280x60 mm (14x11x2.3 inches) suitable for refrigeration boxes up to 200 litres (7 cu.ft.)
Capacity 4701:	Holding plate 355x280x90 mm (14x11x3.5 inches) suitable for refrigeration boxes up to 240 litres (8.5 cu.ft.)
Compressor:	Danfoss BD50F
Voltage:	12/24 Dual volt system
Low voltage protection:	Cut out at 10/21 volt. Automatic re-start when the voltage has been above 12/24 volt for more than 30 sec.
Current consumption:	Low speed approx. 4 A (12 V) High speed approx. 6.5 A (12 V) Stand-by (green LED on) 25 mA (12 V) System switched off 16 mA (12 V)
Fuse:	12 volt :15 A, 24 volt: 7.5 A car type blade fuse (DIN 75281/SAE J 1284)
Refrigerant:	R134a, 145 gram
Water pump:	Flow: 3 l/min (6 pints/min) Max flow: 5 l/min (10 pints/min) Maximum suction height: 2 m (6.5 ft.) Water connections: 13 mm (½”) Current consumption 0.6 A
Dimensions:	Compressor unit 390x200x175 mm (15.4”x7.8”x6.9”)
Weight 4201:	17 kgs (37½ lbs.)
Weight 4701:	21 kgs (46½ lbs.)

Specifications are subject to change without prior notice.

Fault finding chart

Fault	Possible cause	Action
Nothing happens when switched on. All lights off.	No power supply. Reversed polarity.	Is main power switched on? Check fuse.
Green light on. Compressor does not start.	Holding plate cold enough. Temperature sensor not connected. Fault in electronic unit.	No action required. Check cable and connections. Exchange. *
Yellow light flashing. Low voltage cut out.	Battery in poor condition. Voltage drop due to bad cables.	Inspect charging circuit. Measure voltage drop when running and replace cables and terminals if required. Switch off, wait 5 sec. and re-start.
Yellow and red light flashing. Overload sensor cut-out.	Ambient temperature too low, <5°C. Faulty water pump, clogged water inlet. Faulty black electronic unit.	Restarts after 1 min. Compressor too hot, check water pump, filter and hoses. Exchange electronic unit. *
Green light on, red switching on-off.	Shore power battery charger that cannot compensate for higher power consumption when compressor speeds up.	After three attempts within 7 min. compressor automatically locks on low speed and intermediate temperature range.
Compressor runs but no refrigeration generated.	Loss of refrigerant. Connections not tight enough.	Inspect and tighten. Contact specialist to fill refrigerant. *
Compressor runs often but temperature in box not cold enough.	Poor insulation. Open box bottom drainage. Too much gas in the system. Water condenser not cooling correctly.	Re-insulate. Close drainage. Improve water flow to the pump. Specialist to check gas pressure and adjust quantity. *
Compressor running and too cold in the box.	Battery charger or solar panel keeping voltage on high level, above 13.2 volt.	Switch over to MAN.TEMP.
Compressor never stops running: -Not cold enough. -Too cold. -Temp cannot be reduced on MAN.TEMP.	See above. Temp sensor faulty. Temp sensor touching box wall or ice build-up.	See above. Exchange temp sensor. Adjust sensor mounting and defrost.
Compressor keeps running when engine is stopped.	Batteries in excellent condition or extra power source like solar panel or wind generator.	Normal operation. If temp. becomes too cold, switch over to MAN.TEMP.
Compressor will not run on full speed, red light, when engine is running.	Poor charging. Power supply cables too thin. Connections affected by verdigris. Loose fuse.	Check charging system, cables, fuses, terminals and rectify. Clean and grease.

Radio interference when compressor runs.	System is suppressed and fulfils present EMC directives.	Mount power cables as separate as possible from radio equipment. Improve earth connections on radio equipment. Fit additional suppresser. (Part no. 39035)
Fuse blows.	Fault in the electronic unit.	Renew electronic unit * and fuse.

If a complicated fault does occur, such as those requiring specialist assistance please contact Thermoprodukter AB in Kalmar, Sweden, or your local marine distributor for advice.

Thermoprodukter AB
Tel. +46 480 150 80
Fax +46 480 127 75
E-mail: service@isotherm.com

INSTALLATION

Tools required:

In addition to the usual basic hand tools such as screwdrivers, hammer, pliers, assortment of drills, saw, tape measure etc. the following are required:

Small electrical drilling machine, a 30 mm (1¼") hole saw, 21 and 24 mm fixed spanners, crimping pliers for electrical spade type cable connectors.

A sufficient length of cables of suitable diameter for connecting the compressor unit to the battery and an assortment of screws to attach the various components are also required.

General

First, decide where the various components are best situated. Choose a suitable place for the compressor unit at a pipe-run distance of less than 3 m (9½ ft) from the holding plate in the refrigeration box. Try to find a position that requires only gentle, wide radius bends of the pipework. The space intended for the compressor unit should preferably be cool and large and able to be reached by the cables from the battery.

The compressor unit together with its electronics is designed to withstand a normal marine environment. It can be fitted in a splash-free position but should preferably be placed in as dry surroundings as possible. Mount the compressor unit in a horizontal position to allow it to achieve its maximum permitted 30° angle of heel.

The holding plate position in the box should be planned with consideration being taken to the partition, routing of piping, etc. The unit may be fitted in any desired position but must be as high as possible in the box.

Fitting the holding plate

If the box to be used is already in place, inspect it to establish the quality of its insulation, as this is an important thermal efficiency factor. The best insulation materials are polyurethane foam; Bonocell or any other cross-linked expanded polyurethane foam. A good rule-of-thumb is that the thickness of this material should be 0.5 – 1 mm (1/32" # 3/64") per litre (1/4 gallon) of the box. Polystyrene (EPS, EPP, EPE) insulating materials like Frigolite do not insulate sufficiently and should not be used.

The holding plate can be placed in any position. It can be fitted vertically, horizontally, upright or hanging. Due to the fact that cold air always falls downward the holding plate should be placed as high up in the box as possible.

The 6 mm (¼") tinned copper pipe leading from the holding plate can be easily bent allowing it to leave the box in any direction.

The best position for the pipe to exit the box is behind the holding plate in the space formed by the angle supports of the holding plate. The pipe should be handled with care and bent gradually to avoid creasing it. Form it around a suitable cylindrical object if sharp bends are required. Be particularly careful with the thin capillary tube and its connection at the opposite end and don't loosen its two locking turns around the thicker pipe. The pipes are pre-filled with refrigerant and must not be cut.

Start installation by unrolling the pipe to its full extent. Installation of the holding plate is easier if someone can assist. One person can hold the plate and direct the pipe through the side of the box while the other feeds the pipe together with the two connections through the box wall, bulkheads, etc. The holding plate can be screwed either onto the wall or on the underside of the top if space is available. If necessary, it may be easier to mount if openings are cut into the holes in the two supports under the holding plate to suit the diameter of the screws to be used. These screws may then be fitted into the box first and the holding plate "slotted" into place.

Drill the 30 mm (1¼") hole for the pipe and connections as high as possible. This is where it is warmest should any leakage of air occur.

Mount the temperature sensor cable together with the connection pipe through the hole in the box wall.

Fill the hole surrounding the pipe and sensor cable with insulation material. Any excess piping should be coiled in a suitable position outside the box and securely fastened to avoid vibrating.

Partition for adjusting box temperature – Fig. I

See figure on the rear side of the manual.

Cold air from the holding plate sinks down to the bottom of the box. The box, therefore, needs a separate space to enable part of it to be used as a freezer compartment. To achieve best results this compartment should be no larger than absolutely necessary. The partition should be a tight fit against the box sides and reach a height of approximately 5 cm (2") below the top edge of the holding plate.

It should be able to be adjusted vertically 0 – 2 mm (0 – 3/32") to create a gap at the bottom to allow a suitable amount of cold air to flow from the freezer section into the refrigeration section to maintain a temperature of + 4° to + 6°C (39 – 43°F). The dividing partition should not be insulated, be easy to clean and preferably made in transparent plexiglass.

Compressor unit

The compressor unit should be fitted in a horizontal position in a suitable place. If it is positioned in a stowage place a guard may be required for protection. The unit will operate continuously at angles of up to approx. 30°.

The unit should be screwed down well using all fastening holes in the bottom plate to withstand all kind of rough seas and heaving angles.

Installation can often be simplified if the quick coupling connections on the piping and the compressor unit are screwed up tight before the compressor unit is finally tightened down in position. Do not remove the protective caps from the couplings until immediately before that are about to be done and save them for possible future use. The quick coupling connections can be turned by hand to the bottom before continuing tightening steadily and quickly with spanners. While tightening it is important that the male part of the connection stationary is held with a 21 mm spanner so that it does not rotate and damage the thin capillary tube (See fig. D). Tighten the couplings up hard. Use fixed spanners 21 and 24 mm for the couplings.

Sea water connections

The water inlet on the water cooled condenser must be connected to a through-hull fitting that will ensure that cooling water can be fed to the water pump even when sailing. Mount a water filter on the water inlet. Use an easy-to-clean type with a large fine mesh cartridge. The outlet can be connected to an existing through hull fitting such as the drain for the sink if this always is kept open.

Best solution is to mount also a separate outlet fitting to always be sure there is a free water flow for the cooling circuit.

If the water flow is interrupted the refrigeration unit will stop after a while and indicate a malfunction.

The compressor unit can be installed up to 2 m (6½ ft.) above the water level.

To achieve a near-silent operation, a voltage reducer is fitted to the power supply to the water pump. This reduces the speed of the pump and the amount of water flowing through it. After installation, if the cooling water has difficulty in circulation when the pump is dry or after if the system has been drained, push the button (A) for a maximum of 2 minutes. The voltage reduction is then by-passed and the will run at full speed (Fig. G). The voltage reducer gives a constant 5 volt output to the pump independent of the level of the voltage supplied to the voltage reducer (10 – 40 volt).

Recommended water filters: Shurflo 252-3300, Flojet 1740-002, Jabsco-Rule 36400-0000, Whale FV2060.

Control panel

The control panel should be positioned where it can be easily seen and within reach of the 4 m (13 ft.) cable from the electronic unit on the compressor. The housing can be mounted using the accompanying long screws. A 12 mm ($\frac{1}{2}$ ") hole should be drilled for the cable behind the panel. The panel can also be let into its surrounding by removing the plastic housing and attaching it with the accompanying screws.

Electrical wiring

Run a positive lead from the + terminal of the battery or the battery main switch across the accompanying 15 A fuse (for 12 volt system) and a negative lead from the – battery terminal. Connect the power leads to their tab-type terminals on the electronic unit. Be sure not mixing up plus and minus. Minus is above the plus terminal on the red electronic unit.

A spark occurs when the power leads are connected. This is because the electronic units contain capacitors, which are then charged.

Avoid connection of the power cables through switches on a separate switch panel if they are not designed for at least 20 A load.

A battery charger must never be connected directly to the refrigeration system without having a battery connected in parallel. (Fig. J)

Use cables of sufficient cross sections, see table below:

Cable area mm ²	Gauge	Max cable length	
		M / ft. 12 V	M / ft. 24 V
2.5	12	2.5 m / 8 ft.	5 m / 16 ft.
4.0	10	4 m / 13 ft.	8 m / 26 ft.
6.0	10	6 m / 19½ ft.	12 m / 39 ft.
10.0	8	10 m / 33 ft.	20 m / 66 ft.

Connect the temperature sensor cable from the holding plate in the box to the electronic unit in the upper modular connector.

The control cable from the control panel is connected in the lower modular connector on the electronic unit. (Fig. G)

Test run

Start the refrigeration unit by selecting NORMAL.AUTO working mode. The green indicator light comes on immediately and the yellow one shortly after indicating that the compressor is running on low speed. Shortly after, a slight hissing sound can be heard from the holding plate, which after 15 – 30 minutes will show signs of moisture or frost.

Start the engine. Within 1-10 minutes, depending on conditions of the batteries and alternator, the yellow light will go out and the red light will come on and the compressor is speeding up. When the engine is stopped, the voltage in the electrical system drops, within a few minutes the yellow light comes on, the red goes out and the speed of the compressor is reduced.

If the holding plate has reached its full refrigeration capacity, however, the compressor will stop instead. There is always a 30 second delay before the electronic monitoring system takes over.

Finally, check that the electrical wiring and pipework are safe and securely fastened.

Check also all water connections, hose clamps and adaptors.

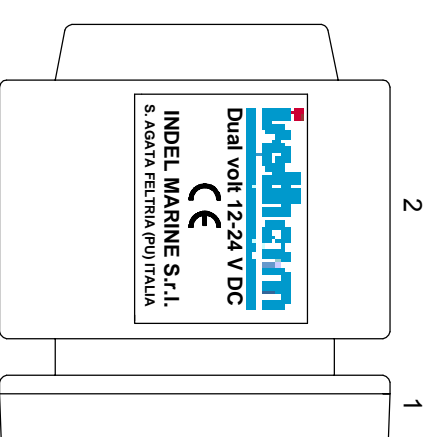
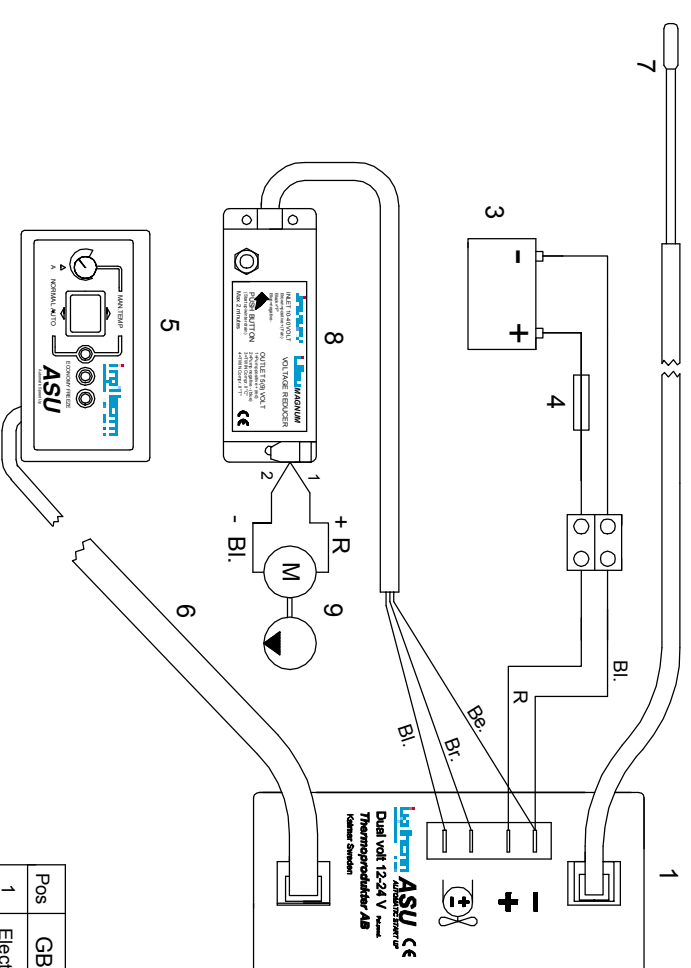

GB	DE	IT	FR	SE
Cable colours	Kabelfarben	Colore cavo	Couleur câble	Kabelfärger
Be.	Bleu	Azzurro	Bleu	Blå
Bl.	Schwarz	Nero	Noir	Svart
Br.	Braun	Marrone	Brun	Brun
R	Rot	Rosso	Rouge	Röd

Pos	GB	DE	IT	FR	SE
1	Electronic unit	Steuereinheit	Centralina	Électronique	Elektronikenhet
2	Electronic ASU	Steuereinheit ASU	Centralina ASU	Électron. ASU	Elektronik ASU
3	Battery	Batterie	Batteria	Batterie	Batteri
4	Fuse 12V-15A 24V-7.5A	Sicherung 24V-7.5A	Fusibile 12V-15A 24V-7.5A	Fusible 24V-7.5A	Säkring 24V-7.5A
5	Control panel	Schaltpanel	Pannello di contr.	Tableau de contr.	Manöverpanel
6	Control cable	Kabel für Schaltpan.	Cavo di contr.	Cable de contr.	Manöverkabel
7	Temp. sensor	Thermistor	Sensore di temp.	Cateur de temp.	Termistor
8	Voltage reducer	Spannungsreduziter	Trasformatore	Voltage baissier	Spänningssänkare
9	Water pump	Wasserpumpe	Pompa acqua	Pompe à eau	Vattenspump

Fig. G

Isotherm ASU Magnum 4201 & 4701

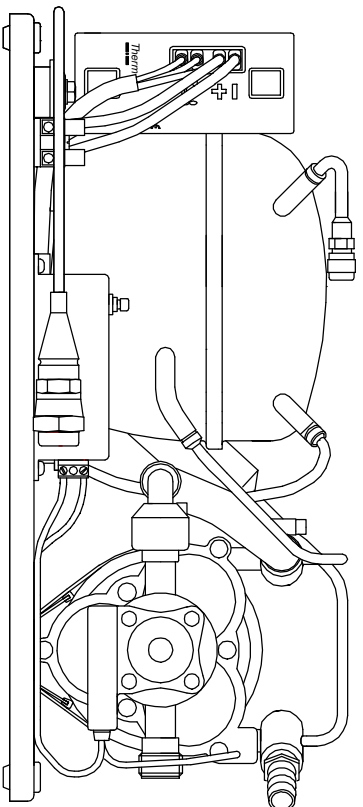

↑
Watten ut
Water out

↑
Watten in
Water in

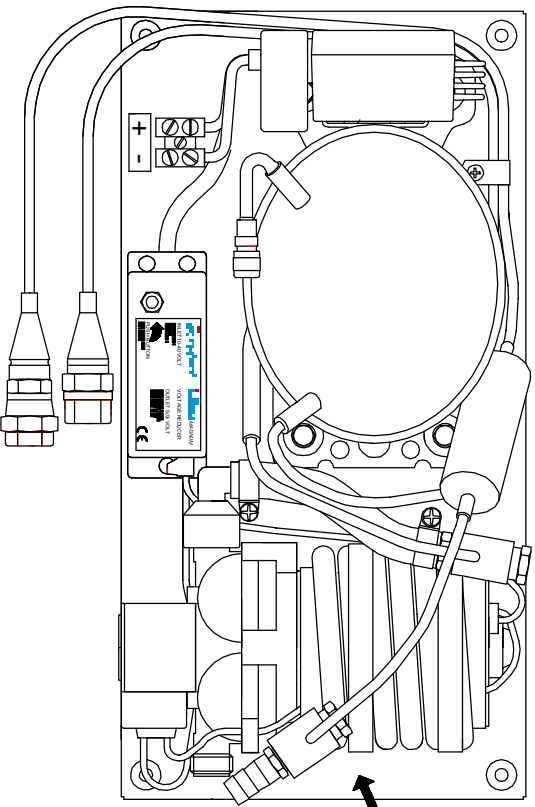

Zinkanod
Zink Anode
Zinc anode

↑
Watten ut
Water out

↑
Watten in
Water in

RevNo/Revision note

Date

Signature Checked

Standard	Quantity	Title/Name, designation, material, dimension etc	Article No./Reference
Designed by	Checked by	Approved by - date	Date
			020110/LLG
Owner		Title/Name	Scale

Water connection 4201-4701



Drawing number
000611

Edition
Sheet



Pump Service Notes for Isotherm Magnum Water-cooled systems.

All Isotherm water-cooled systems built after 1994 use a Shur-flo pump to provide the supply of cooling water. It is very important that the pump and condenser are functioning properly. If the pump is not functioning properly the system may:

- Draw high current
- Run hot
- Cool inefficiently or not at all.

It will also be impossible to access the refrigerant charge until pump and condenser are operating properly.

The 12V pump operates a reduced voltage (5VDC) to supply the flow of approx .5 gallons per minute at approx .5 amp draw.

Normally the pump produces very little noise, any change or increase in the noise level may indicate a pump problem or a restriction in the plumbing or condenser.

The condenser should be flushed out and zinc changed once a year. Isotherm now installs only one zinc on the condenser - near the outlet fitting. If there are two zincs remove the zinc near the condenser inlet and replace it with a 1/4" NTP plug. The zinc is a standard 1/4 " NPT zinc pencil that has been shortened to 3/8 " (a longer zinc may block the water flow)

The water pump valves should be changed at least every two years. Do not attempt to service or clean the valves - **change them**. As the valve material ages the seals will no longer perform.

For the best service life use a large 40 mesh strainer before the pump inlet and mount this strainer where it is easy to service.

Two strainers that will give good results are:
Shur-Flo Model 252-3300 Or Flo-Jet Model 01740-002

The part number of the Valve Assembly is # **15-P-SF_valve** and comes with an instruction sheet.

A complete pump is Part # **15-P39541** It is supplied with a mounting base – when replacing this pump consider mounting it separately - away from the compressor if this will improve access for servicing the pump.

Replacement ¼ NTP pencil zincs are available at West Marine part # 332155
The standard zinc is too long & must be hack sawed down to 3/8 length.