

## **ISOTHERM 4200/5200/5700 INSTRUCTIONS**

### **General**

ISOTHERM 4200/5200/5700 MAGNUM “ASU - Automatic Speed Up” is a modern sea water cooled refrigeration system for sailing yachts and motor cruisers. It is designed to generate low refrigeration temperatures even in hot conditions while at the same time consuming an absolute minimum of battery power. This is achieved by using a patented electronic control system which runs the refrigeration compressor at 50 % higher speed when the boat’s engine is running. This, in combination with a holding plate inside the refrigerator, stores the refrigeration energy produced for long periods.

The easy do-it-yourself installation requires no connections to either the engine or its cooling system.

*The following points are important if good results are to be achieved.*

### **Refrigerator box**

To retain as much cold air as possible when opened, a top-loading box is usually preferable to a side opening one.

A most important factor in achieving good results is that the refrigeration box is well-insulated. Do not use polystyrene-type insulation material. Expanded or cross-linked PVC or polyurethane insulation material should be used.

Recommended minimum thickness (multiply by 3 for freezer boxes): 30 mm for a 50 litre box; 50 mm for a 100 litre box and 75 - 100 mm for larger boxes. If space is available use thicker insulation around the lower part of the box.

A moveable partition should be installed in the box to allow the Cozen food section surrounding the cold plate to be reduced to the smallest space possible so that the correct temperature of 4 - 6” (39 - 43°F) can easier be maintained in the refrigeration section.

The lid must also be insulated but more important that it fits tightly into the opening.

If a water drain is fitted in the bottom of the box, this must always be closed during use to avoid cold air from running out and warm, damp air entering.

### **Electrical system**

An electrical system that is both correctly dimensioned and in good working order is required. This is especially important if the refrigeration system is to operate continuously for a few days during warm weather and not have to start the engine for charging.

Calculate the boat's total power requirements. The engine should always have a separate battery for starting. In addition to the battery capacity required by other electrical equipment onboard, one extra 75 Ah battery will be sufficient for the refrigeration power supply. In addition to increasing the amount of "standby-power" available onboard, the extra service battery can also store surplus power when this is being generated by the engine. Two batteries can, of course, accept twice the amount of charge. The alternator is normally not a limiting factor. All service batteries must have generously-dimensioned cables for both positive and negative circuits if they are to receive full charging voltage from alternator.

### **Using the refrigerator**

Power consumption is dependant to a large degree on how the refrigerator is used.

Let refrigerated food remain inside the fridge as far as possible and take them out only when required. Don't leave them out of the fridge longer than absolutely necessary when cooking or having your meal. Replace them as quickly as possible.

**ir**

Avoid placing warm food in the fridge. If possible, use an insulated thermal bag when carrying frozen or chilled foodstuffs from home or the shops.

Let the engine run a few minutes extra when leaving and entering harbour. The engine alternator will then supply an extra boost of refrigeration energy just when needed, i.e. immediately before "no-power" periods of sailing and in harbour.

### **Refrigeration temperatures**

The correct temperatures for storing sensitive foodstuffs such as meat, fish, milk, etc. are as follows:

#### **Internal temperature of refrigerated food.**

10°C (50°F)

8°C (46°F)

6°C (43°F)

4°C (39°F)

1°C (34°F)

#### **Duration after which food can become unfit for consumption.**

1 day or less

1-2 days

2-3 days

5 days

5-7 days

The correct way to store refrigerated food is to never allow its temperature to exceed 6°C (43°F). Switching off the refrigerator overnight is a false economy and from a hygienic point-of-view is not recommended.

# MAIN COMPONENTS

ISOTHERM refrigerator systems consist of three main components: the Compressor Unit, the Holding Plate and the Control Panel.

## **Compressor Unit** - (Fig. A)

The GE-type refrigeration compressor is of the very latest design. It produces extremely high refrigeration energy while consuming very little battery power. As it is driven by 12 or 24 volt 3-phase alternating current, it has an unbeatable starting ability and its speed and capacity can be regulated. It is of the same totally-hermetic design as that of domestic refrigerators and has, therefore, a long operating life, low sound level, and is completely maintenance-free. The piston-type compressor operates on a mixture of cooling medium and oil. It is to be fitted horizontally with its feet downwards but it will operate at a continuous angle-of-heel of up to 30° in all directions. Should this angle be exceeded, the compressor will stop automatically. It will re-start automatically when the angle has been reduced.

The compressor is integral with the water cooled condenser which is equipped with a waterpump.

The compressor unit is delivered pre-filled with cooling medium and has irreversible, quick-coupling connections on the ends of the flexible piping which connects it to the holding plate. These couplings can be disconnected and re-connected should either unit need re-positioning.

To simplify connecting up the system, the electronic control unit mounted on the left side of the compressor is fitted with screw-type terminals for the positive and negative main power cables; large modular (telephone type) connectors for the 4 metre cable to the control panel; and small modular connectors for the 3.5 metre cable for the temperature sensor on the rear of the holding plate. It contains a micro-processor with programmed functions for slow-running; speeding-up the compressor when the engine is running; battery monitoring for high and low voltage (cut-out at 10.20 volt, cut-in 12/24 volt); monitoring of low and high speed and power consumption; regulating the holding plate temperature; transmitting signals to the control panel such as flashing indicator lights should there be a malfunction. The compressor together with its electronic unit fulfils applicable radio interference regulations and is CE-marked.

When connected to shore power, a high-quality battery charger of minimum 20 Amp output should be used. This must always be connected to the boat's service batteries and never directly to the control unit. When using shore-power, the Control Panel should be in the "MAN.TEMP" position.

### **Holding Plate - (Fig. B)**

The holding plate is a hermetic, stainless-steel container holding a special freon-free cooling medium which freezes to ice when the engine is running. The freezing point of the liquid is normally  $-8^{\circ}\text{C}$  ( $17^{\circ}\text{F}$ ). The holding plate is connected to the compressor unit by a pliable, 3 metre long tinned copper pipe of 6 mm diameter fitted with quick-coupling connections. The holding plate must be fitted as high as possible in the refrigerator. It may be installed in any vertical or horizontal position required and at any level above or below that of the compressor unit.

A temperature sensor is fitted to the rear of the holding plate. This is to be connected to the compressor unit by the 3.5 metre cable supplied and can suitably follow the same route as the 3 metre connecting pipe. This pipe (together with the compressor and holding plate) is pre-filled with exactly the correct amount of cooling medium and on no account should any attempt be made to either shorten or lengthen it. If the pipe is too long, the excess should be made into a coil at some suitable position. If a longer pipe is required, a pre-filled 2.5 metre extension pipe (Part No. 39045) is available. A 2.5 metre extension for the temperature sensor cable (Part No. 39232) is also available.

### **Control Panel - (Fig. C)**

The control panel is equipped with a three-way switch; green, yellow and red indicator lights; and a rheostat for manual temperature adjustment when running on shore-power or a solar panel.

Inside the control panel box is a modular connector for the 4 metre cable from the electronic control unit on the compressor. Should this require extending, use the 10 metre long accessory cable (Part No. 39230) instead.

## **OPERATION**

The ISOTHERM refrigeration system can be operated in two ways. When energy saving is needed, switch to "NORMAL.AUTO" position. Optimum refrigeration temperature is then automatically maintained while consuming the lowest amount of battery power possible. When there is no need of energy saving, switch to "MAN.TEMP" position. The automatic function is now partially blocked and refrigeration temperature can be manually adjusted (Fig. C). In its centre position, the ISOTHERM unit is switched off.

### **"NORMAL.AUTO" position:**

The green light indicates that power is being supplied and the refrigeration programme is activated.

When the engine is running and the voltage supply (measured at the compressor's control unit) is over 13.2 (26.4) volt, the compressor starts to supply cooling energy to the holding plate. It starts within the first 15 seconds and operates first at low speed with the yellow "Economy" indicator lit.

After about two minutes, the speed of the compressor and cooling fan increases by 50% and the red "Freeze" indicator lights. This operating condition is maintained until the holding plate is completely frozen at approximately  $-14^{\circ}\text{C}$  ( $7^{\circ}\text{F}$ ). This can take between 45 minutes and 2 hours depending on the model, ambient temperature and box size. On reaching this temperature, the compressor stops and red light goes out. When the temperature of the holding plate rises to  $-10^{\circ}\text{C}$  ( $14^{\circ}\text{F}$ ), the compressor re-starts to charge the holding plate and the red light comes on again. This process is repeated a couple of times every hour keeping the holding plate at its optimum efficiency level. When the engine is stopped, the compressor also stops shortly afterwards.

When the engine is stopped and the battery voltage is below 12.7 (25.4) volt, the surplus of refrigeration energy stored in the holding plate is used first. Only when this has been consumed does the compressor start. The yellow light indicates that it is now running at its low "Economy" speed to "top-up" the holding plate only. This condition starts when the temperature of the holding plate rises to  $-1^{\circ}\text{C}$  ( $30^{\circ}\text{F}$ ) and stops when it reaches economy level of  $-6^{\circ}\text{C}$  ( $21^{\circ}\text{F}$ ).

### **"MAN.TEMP" position:**

This position can be used either when shore-power or solar panels are being used or when energy saving is not required and a higher or lower refrigerator temperature is desirable for some reason. The automatic function is blocked and the temperature regulated by means of the rheostat - clockwise for colder and anti-clockwise for warmer. "A" indicates the holding plate temperature point for "Accumulation". In the "MAN.TEMP" position, the compressor starts to

maintain the temperature chosen but runs somewhat more as it has an unlimited supply of power (shore or solar panel). It runs at low speed only and, as the engine is stopped, with a very nearly inaudible level of sound.

### **Indicator lights**

- Green: Power and system on, but compressor at stand-still due to sufficiently low temperature of holding plate.
- Green+yellow: Compressor running at low speed keeping the holding plate cool but without charging it.
- Green+red: Compressor running at top speed for “charging” the holding plate. .
- Green+yellow+red: Compressor running at low speed in “MAN.TEMP” mode.
- Flashing yellow+red: Battery charger operating on shore power not capable of sufficient voltage when compressor is running at top speed. Switch over to “MANTEMP” position.
- Flashing yellow: Low battery voltage sensor has switched off the system. Automatic re-start occurs when engine is started to charge batteries again.
- Flashing red: Overload sensor has switched off system due to high temp., thick oil during winter, etc. Re-start by switching off for 5 sec. before switching on again.

Note: The compressor will start 5-30 seconds after switching on. When the engine is started, 5-10 minutes is required (depending on the boats charging equipment and battery condition) before the system reacts. When the engine is stopped, 5-10 minutes is required (depending on battery condition and level of charge) before the system reacts.

### **Maintenance**

If the quick-coupling connections have been tightened correctly during installation, the totally-hermetic ISOTHERM system will never require refilling with cooling medium. Maintenance is limited to removing dust on the condenser and compressor unit, regular check-up and replacement of the zinc anodes, cleaning the water filters, defrosting the holding plate when required and keeping the inside of the refrigerator dry. It is of vital importance that the batteries and charging system are kept in good condition.

The complete system should remain in the boat during winter, but it may not always be able to be started at ambient temperatures below freezing.

Drain the water pump and filters if temperatures below freezing point are expected.

## Safety Instructions

- When connected to shore-power, ensure that the power supply is equipped with an accidental-ground automatic switch. **Danger!**
- Never touch bare electric wiring connected to the mains supply. **Danger!**
- Never open the cooling circuit except by the quick-couplings which are designed specifically for that purpose.
- Never connect a battery charger directly to the refrigeration system. It must always be connected to the battery. In addition to acid, a newly-charged battery contains explosive gas. **Danger!**
- Never cover up the ventilation openings for the compressor unit.

## Technical Data

Type designations:	4201 12 volt with 355x270~60 mm holding plate
	4202 24 volt -    -
	5201 12 volt with 355x270x90 mm holding plate
	5202 24 volt -    -
	5701 12 volt with 400x320x90 mm holding plate
	5702 24 volt -    -
Capacity:	Suitable for refrigeration boxes up to
	4200 200 litres (7 cu.fi.). As freezer 55 litres (2 tuft).
	5200 250 lib-es (10 cu.fi.).As freezer 80 litres (3 cu.@
	5700 325 litres (12 cult). As freezer 100 It. (3% CUB).
Voltage:	12 (10.5-16) volt
	24 (21-32) volt
Power consumption:	Low speed - approx. 5-6A (5200/5700 10A) 50% - 24v
	High speed - approx. 7-9A ( - " - 15A) - " -
	Stand-by (green lamp on) - 15 mA - " -
	System switched off - 7 mA - " -
Fuse:	Separate holder for U-shaped fuses of car-type.
	4200 20 A for 12 V, 15 A for 24 V
	5200 30 A for 12 V, 20 A for 24 V
	5700 30 A for 12 V, 20 A for 24 V
Cooling medium:	R134a (quantity stated on model identification plate)
	fi-ee from freon.
Water pump:	Flow rate: 2 l/mm (4 pints/min).
	Maximum suction heigh: 2 m (6.5 ft.).
	Current consumption: 0.6A
	Water connections: 13 mm (1/2")
	Maximum water temp.: 35°C (93°F)
Weight:	4200 19 kgs
	5200 20 kgs
	5700 25 kgs

# INSTALLATION

## Tools required

In addition to the usual basic hand tools such as screwdrivers, hammer, pliers, assortment of drills, saw, tape measure, etc., the following are required: Small electric drilling machine; a 30mm hole-saw drill; a 12mm drill; a 2 lmm and a 24 mm fixed spanner; crimping pliers for electrical spade-type connectors. A sufficient length of electric cable of suitable diameter for connecting the compressor to the battery and an assortment of screws to attach the various components are also required.

## General

First, decide where the various components are best situated. Choose a suitable place for the compressor unit at a pipe-run distance of less than 3 metre from the box. Try to find a position that requires only gentle, wide-radius bends on the pipework. The space intended for the compressor should preferably be cool and large and able to be reached by the cable from the battery.

The compressor space chosen should also be within a cable-run distance of less than 4 metre from that of the control panel. The compressor unit, together with its electronics, is designed to withstand a normal marine environment. It can be fitted in a splash-free position but should preferably be placed in as dry surroundings as possible. **Mount the compressor in a horizontal position** to allow it to achieve its maximum permitted 30° angle of heel.

The holding plate position in the box should be planned with consideration being taken to the partition, routing of piping, etc. The unit may be fitted in any desired position but must be as high as possible in the box.

## Fitting the holding plate

If the box to be used is already in place, inspect it to establish the quality of its insulation as this is an important thermal efficiency factor. The best insulation materials are polyurethane foam, Dinivycell, Bonocell or any other cross-linked expanded polyurethane plastic foam. A good rule-of-thumb is that the thickness of this material should be OS- 1 mm per litre volume of the box. Polystyrene insulating materials of type Frigolit, Rockwool, etc., do not insulate sufficiently and should not be used.

The holding plate can be placed in any position. It can be fitted vertically, horizontally, upright or hanging. Due to the fact that cold air always “falls” downward, the holding plate should be positioned as high up in the box as possible as good refrigeration cannot be achieved above this level.

The 6 mm copper pipe leading from the holding plate can be easily bent over the edge of the plate, thereby allowing it leave the box in any direction.

The best position for the pipe to exit the box is behind it in the space formed by the corner supports of the holding plate. The pipe should be handled with care

and bent gradually to avoid creasing it. Form it around a suitable cylindrical object if sharp bends are required. Be particularly careful with the thin capillary tubing and its connection at the opposite end, and don't loosen its two locking turns around the thicker pipe.

The pipes are pre-filled with cooling medium and **must not be cut**. Start by unrolling the pipe to its full extent. Installation of the holding plate is easier if someone can assist. One person can hold the plate and direct the pipe through the side of the box while the other feeds the pipe together with the two connections through bulkheads, etc.

The holding plate can be screwed either onto the wall or on the underside of the top if space is available. If necessary, it may be easier to mount if openings are cut into the holes in the two supports under the holding plate to suit the diameter of the screws to be used. These screws may then be fitted into the box first and the holding plate "slotted" into place.

Drill the 30 mm hole for the pipe and connections as high as possible under where the holding plate is to be fitted. This is where it is warmest should any leakage of air occur. Fill the hole surrounding the pipe with insulation material. Any excess piping should be coiled in a suitable position outside the box and securely fastened to avoid vibrating.

### **Partition for adjusting box temperatures (Fig. 1)**

Cold air from the holding plate sinks down to the bottom of the box. The box, therefore, needs a separate space to enable part of it to be used as a freezer compartment. To achieve best results, this compartment should be no larger than absolutely necessary. The dividing partition should be a tight fit against the box sides and reach a height of approximately 5 cm (2 in.) below the top edge of the holding plate.

It should be able to be adjusted vertically from 0-2 mm to create a gap at the bottom to allow a suitable amount of cold air to flow from the freezer section into the refrigeration section to maintain a temperature of +4-6°C (39-43°F). The dividing partition should not be insulated, be easy to clean and preferably made of transparent Plexiglas.

### **Compressor unit**

The compressor unit should be fitted on its supports in a horizontal position in a suitable place such as a cupboard, wardrobe, stowage compartment, etc. Using two strong 90° angle brackets (Part No. 30012), the unit can also be mounted onto a suitable bulkhead, under the side decks or any other place where no valuable stowage space will be lost. If it is positioned in a stowage place, a guard may be required for protection.

The unit will operate continuously at angles of up to approx. 30° and should therefore be fitted horizontally across the beam of sailing boats so as not to

exceed this at full angle of heel. The unit should be screwed down well to withstand rough seas.

Installation can often be simplified if the quick-coupling connections on the piping and the compressor are screwed up tight before the compressor unit is finally tightened down in position. Do not remove the protective caps until immediately before this is about to be done and save them for possible future use. The quick-coupling connections can be turned by hand for the first few threads before continuing tightening steadily and quickly with a spanner so that the connections enter its sealing position and the valves open. While doing this, it is important that the male part of the connection stationary is held with a 21 mm spanner so that it does not rotate and damage the thin capillary tube (see Fig. D). Tighten the couplings up hard. Use fixed spanners 21 and 24 mm for the pipe fittings.

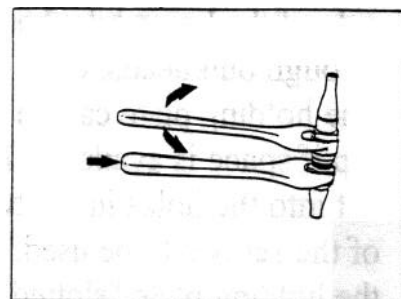
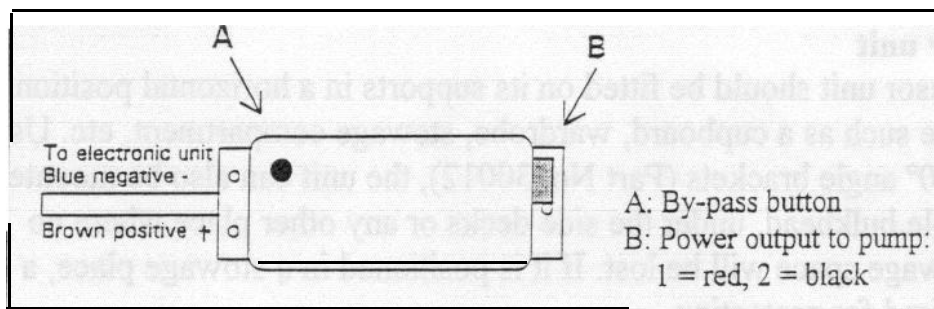

Fig. D

### Sea water connections

The water inlet on top of the pump must be connected to a through-hull fitting that will ensure that cooling water can be fed to the compressor even when sailing. Mount an additional in-line, easy-to-clean water filter on the water inlet side of the water pump. The outlet can be connected to an existing through-hull fitting, such as the dram for the sink. The compressor can be installed up to 2 meters above water level.

To achieve near-silent operation, a voltage reducer is fitted to the power supply to the water pump. This reduces the speed of the pump and the amount of water flowing through it. After installation, if the cooling water has difficulty in circulating when the pump is dry or after if the system has been drained, push the button (A) for a maximum of 2 minutes. The voltage reduction is then by-passed and the pump will run at full speed (Fig. E). The voltage reducer gives a constant 5 volt output to the pump independent of the level of the voltage supplied to the voltage reducer (10 - 40 volt). This component (Part No.39542) is used for both 12 and 24 volt.



### Control panel

The control panel should be positioned where it can be seen easily and within reach of the 4 meter cable from the electronic control box on the compressor. The

housing can be mounted using the accompanying long screws. A 12 mm o hole should be drilled for the cable. The panel can also be let into its surrounding by removing the plastic housing and attaching it with the accompanying screws.

## Electrical wiring

Run a positive lead from the plus (+) terminal of the battery or the battery main switch across the accompanying fuse holder (Fig. F) and a negative lead from the negative (-) battery terminal. **For a 12 Volt system, the minimum area of the cable from the battery to compressor must be: 4 mm<sup>2</sup> if the length is less than 2.5 meter; 6 mm<sup>2</sup> if up to 6 meter; and 10 mm<sup>2</sup> if up to 10 meter.** These areas can be halved for a 24 volt system but never less than 4 mm<sup>2</sup>.

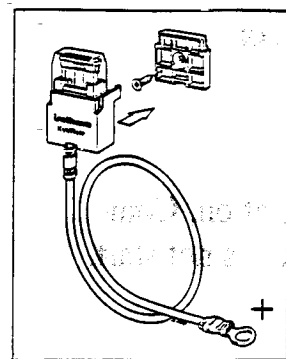

Fig. F

Connect these cables to their correct screw terminals on the control unit. The fuse will blow if the connections are reversed. A battery charger must never be connected directly to the refrigeration system without having a battery connected in parallel (Fig. H).

A spark occurs when the power leads are connected. This is because the control unit (which consumes only 7 mA in its closed circuit condition) contains a capacitor which is then charged.

Connect the two modular plugs on the side of the control unit with the control panel cable plug connected to the larger one (Fig. G).

## Test run

Set the switch to "NORMILAUTO". The green light goes on immediately and the yellow one shortly after indicating that the compressor is running at low speed. Shortly after, a slight hissing sound can be heard from the freezer unit which after 15-30 minutes will show signs of moisture or frost.

Start the engine. Within 2-10 minutes (depending on condition of the batteries and alternator) the yellow light will go out, the red one lights and the compressor start running at high speed.

When the engine is stopped, the voltage in the electrical system drops. Within a few minutes, the yellow light comes on, the red goes out and the speed of the compressor is reduced. If the holding plate has reached its full retigeration capacity, however, the compressor will stop instead. There is always a 30 second delay before the electronic monitoring system takes over (2% min. the first time). Finally, check that the electrical wiring and pipework are safe and securely fastened.

# FAULT-FINDING CHART

~Fault	Possible cause	action
Nothing happens when switched on. All lights off.	~No power supply. Check fuse.	Is main power switch on?
Green light on. Compressor does not start.	~Holding plate cold enough. Temperature sensor not connected. Fault in control unit	No action required. Check cable.  Replace
Yellow light flashing. Low voltage cut-out when activated.	Battery in poor condition. Voltage drop due to thin cables.	Inspect charging circuit. Measure voltage drop running and replace cables if required. Switch off, wait 5 sec. and restart.
Red light flashing. Overload cut-out activated.	Oil in compressor too thick at temp. 6°C. Faulty waterpump, clogged water inlet.	Frequent restarts as above. Compressor hot. Check water pump, filter and hose.
~Yellow/red lights flashing.	Shore-power driven charger that cannot compensate when compressor runs at high speed.	Switch to "MAN.TEMP" and choose suitable temp. on control panel.
Compressor runs but no refrigeration generated.	Loss of cooling medium. Connections not tight enough.	Inspect and tighten. Contact specialist to fill cooling medium*.
Compressor runs often but temp. in box not cold enough. compartment.	Poor insulation. Too warm in compressor compartment.  Too much gas in system. (Frost on pipe).	Re-insulate. Improve ventilation of compressor.  Specialist to check gas pressure and adjust quantity*.

<p>Compressor never stops running:          -Not sufficiently cold.          -Too cold.          -Temp. cannot be reduced manually. system.</p> <p>Compressor keeps running when engine stopped.</p>	<p>See above.          Temp. sensor faulty.          Temp. sensor touching box wall or ice build-up. _ =</p> <p>Batteries in excellent condition, or extra power source (solar panel, wind generator, etc.)</p>	<p>S e e a b o v e .          Renew.          Adjust sensor or defrost by switching off.</p> <p>Normal operation.          If temp. becomes too is cold switch to "MAN.TEMP" .</p>
<p>Compressor will not run at M1 speed and red light not on when engine is running.</p>	<p>Poor charging. Plus or minus cables too thin.          Connections affected by verdigris, loose fuse.</p>	<p>Check charging, cables and rectify.          Clean and grease.          (Correct voltage &gt; 13.4 v measured at control unit with compressor and engine running).</p>
<p>Radio interference when running.  </p> <p>~Fuse blows.</p>	<p>System is suppressed and fuhils present regulations.</p> <p>Crossed +/- leads. Fault in control box.</p>	<p>Fit additional surpressor.          Part no. 39035 (20 A Puresound).</p> <p>Renew fuse or control box*.</p>

If a complicated fault does occur, such as those requiring specialist assistance (marked \*), please contact Thexmoprodukter AB in Kalmar, Sweden, or your local marine distributor for advice.

Thermoprodukter AB has a year-round 24-hour service fax to take your inquiries. The number is +46 480 12775.

# ELANSLUTNING / ELECTRICAL CONNECTIONS

ASU

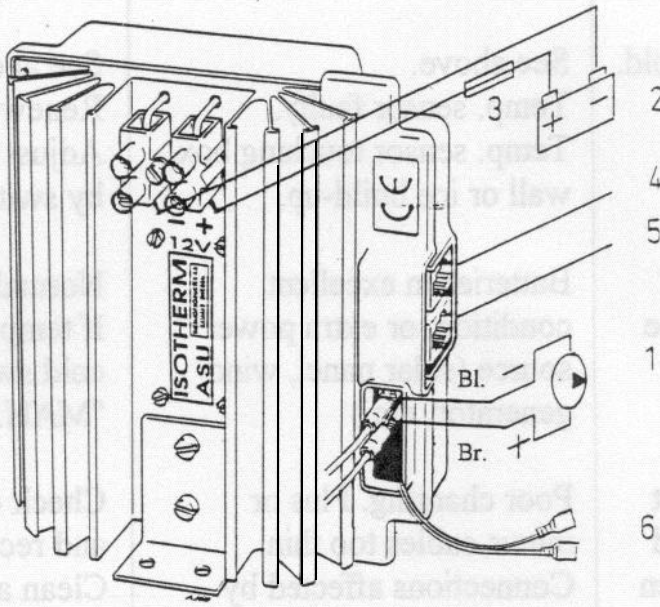

1. Anslutning vattenpump. Water pump connection.
2. Batterianslutning. Battery connection.
3. Säkring. Fuse.
4. Anslutning termistorkabel från kylmagasin. Connection temperature sensor from holding plate.
5. Anslutning kabel från manöverpanel. Connection cable from control panel.
6. Anslutning överhettningsskydd. Connection overheat protection.

Fig. G

Batter&dare  
Battery charger

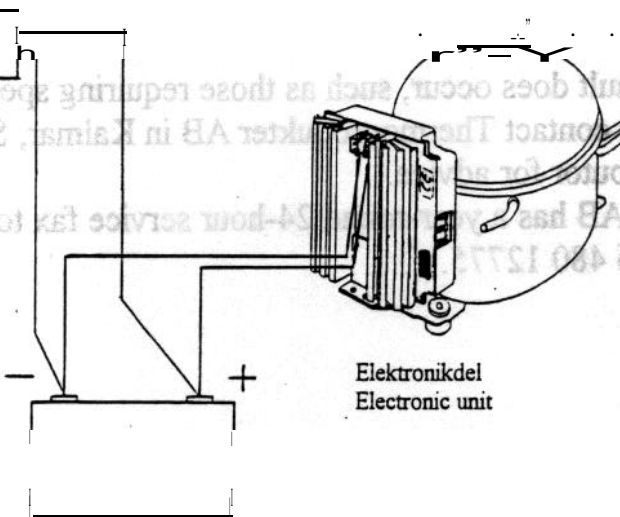

Fig. H



# ISOTHERM 4200/5200/5700 MAGNUM

## Reservdelar/Spare parts/Ersatzteile/Pieces detachees

- ~39405 Kompressorenhet 4200 12 volt komplett exkl. eldel.  
Compressor unit 4200 12 volt complete excl. electronic unit.  
Kompressoreinheit 4200 12 volt komplett ohne Steuereinheit.  
Compressur 4200 12 volt complets\_ans unite Electronique.
- ~39406 Kompressorenhet 4200 24 volt komplett exkl. eldel.  
Compressor unit 4200 24 volt complete excl. electronic unit.  
Kompressoreinheit 4200 24 volt komplett ohne Steuereinheit.  
Compressur 4200 24 volt complet sans unite electronique.
- ~39534 ~Kompressorenhet 5200/5700 12 volt komplett exkl. eldel.  
Compressor unit 5200/5700 12 volt complete excl. electronic unit.  
Kompressoreinheit 5200/5700 12 volt komplett ohne Steuereinheit.  
Compressur 5200/5700 12 volt complet sans unite Electronique.
- ~39535 Kompressorenhet 5200/5700 24 volt komplett exkl. eldel.  
Compressor unit 5200/5700 24 volt complete excl. electronic unit.  
Kompressoreinheit 5200/5700 24 volt komplett ohne Steuereinheit.  
Compressur 5200/5700 24 volt complet sans unite Electronique.
- ~3903 1 Kylmagasin 4200 komplett med rör och snabbkopplingar.  
Holding plate 4200 complete with pipes and couplings.  
Kahespeicher 4200 komplett mit Rohr und Kupphngen.  
Plaque r&gerante 4200 complete avec tubes et raccord.
- 39506 Kyhnagasin 5200 komplett med rör och snabbkopplingar.  
Holding plate 5200 complete with pipes and couplings.  
Kahespeicher 5200 komplett mit Rohr und Kupphngen.  
Plaque rCf?egerante 5200 complete avec tubes et raccord.
- 39537 ~Kyhnagasin 5700 komplett med rör och snabbkopplingar.  
Holding plate 5700 complete with pipes and couplings.  
Kahespeicher 5700 komplett mit Rohr und Kupphngen.  
Plaque reti-egerante 5700 complete avec tubes et raccord.
- 39532 Styrssystem 12 volt.  
Electronic unit 12 volt.  
Steuereinheit 12 volt.  
Unite Electronique 12 volt.

- ~39533 Styrssystem 24 volt.  
Electronic unit 24 volt.  
Steuereinheit 24 volt.  
Unite Electronique 24 volt.
- ~39242 Manoverpanel 12/24 volt.  
Control panel 12/24 volt.  
Kontrolleinheit 12/24 volt.  
Tableau de controle 12/24 volt.
- ~39228 Termistor med kabel 3,5 m.  
Temperature sensor with cable 3.5 m.  
Thermistor mit Kabel 3,5 m.  
Cateur de temperature avec cable 3.5 m.
- 39229 Manoverkabel for kompressor 4 m.  
Control cable 4 m.  
Kabel flir Kontrolleinheit 4 m.  
Cable de controle 4 m.
- 39230 Manoverkabel for kompressor 10 m.  
Controle cable 10 m.  
Kabel flir Kontrolleinheit 10 m.  
Cable de controle 10 m.
- ~39017 Arislutningsror komplett med kopplingar.  
Connection pipes complete with couplings.  
Anschlussrohr fGr Kahespeicher, komplett mit Kupphmgen.  
Tube de reccordement complet pour plaque retiigerante.
- ~39518 Vattenfilter.  
Water filter.  
Wassexfilter.  
Filtre a eau.
- ~39541 Vattenpump.  
Waterpump.  
Wasserpumpe.  
Pompe a eau.





Pump Service Notes for Isotherm Magnum Water -cooled systems.

All Isotherm water-cooled systems built after 1994 use a Shur-flo pump to provide the supply of cooling water. It is very important that the pump and condenser are functioning properly. If the pump is not functioning properly the system may:

- Draw high current
- Run hot
- Cool inefficiently or not at all.

It will also be impossible to access the refrigerant charge until pump and condenser are operating properly.

The 12V pump operates a reduced voltage (5VDC) to supply the flow of approx .5 gallons per minute at approx .5 amp draw.

Normally the pump produces very little noise, any change or increase in the noise level may indicate a pump problem or a restriction in the plumbing or condenser.

The condenser should be flushed out and zinc changed once a year. Isotherm now installs only one zinc on the condenser - near the outlet fitting. If there are two zincs remove the zinc near the condenser inlet and replace it with a 1/4" NPT plug. The zinc is a standard 1/4 " NPT zinc pencil that has been shortened to 3/8 " (a longer zinc may block the water flow)

The water pump valves should be changed at least every two years. Do not attempt to service or clean the valves - change them. As the valve material ages the seals will no longer perform.

For the best service life use a large 40 mesh strainer before the pump inlet and mount this strainer where it is easy to service.

Two strainers that will give good results are:  
Shur-Flo Model 252-3300 Or Flo-Jet Model 01740-002

The part number of the Valve Assembly is # 15-P-SF\_valve and comes with an instruction sheet.

A complete pump is Part # 15-P39541 It is supplied with a mounting base – when replacing this pump consider mounting it separately - away from the compressor if this will improve access for servicing the pump.

Replacement ¼ NTP pencil zincs are available at West Marine part # 332155  
The standard zinc is too long & must be hack sawed down to 3/8 length.